

**HAMMELMANN®**



# THOROUGH CLEANING OF TANKS, VESSELS AND CONTAINERS

AQUAMAT and AQUAREX® tank cleaning systems

For various diameters

For tank openings as little as Ø 98 mm

Minimum pressure loss

Operating pressure up to 1800 bar

Great reliability

Versatile application







The logo consists of the word "HAMMELMANN" in a bold, black, sans-serif font, followed by a registered trademark symbol (®). The text is centered within a bright yellow rectangular background.

**HAMMELMANN®**

The background of the page is a dark, monochromatic photograph of an industrial tank cleaning unit. On the left side, a vertical pipe assembly is visible, featuring a circular access panel with a hexagonal bolt pattern. A flexible hose is connected to the side of the unit, and a spray lance is attached to the end of the hose, emitting a fine mist of water. The overall scene is dimly lit, emphasizing the textures and metallic surfaces of the equipment.

**AQUAMAT**  
TANK CLEANING UNITS

## CLEAN TANKS AND CONTAINERS THOROUGHLY AND QUICKLY

Hammelmann tank cleaning units remove deposits and incrustations from the inner and outer walls of tanks and tank installations at operating pressures of up to 1800 bar. The units operate solely using the recoil force of the water jet. Hammelmann offers a wide range of nozzle holders for various applications. The tank cleaning units can be fitted with one or two nozzle holders.



**AQUAMAT S 600**

Cleaning of an ASF container



### EXTREMELY POWERFUL

Efficient cleaning performance thanks to high operating pressures (up to 1800 bar) and high flow rates (up to 700 l/min).



### EFFECTIVE AND ENVIRONMENTALLY FRIENDLY

Hammelmann tank cleaning units are developed with performance and sustainability in mind. The high efficiency of the systems makes their use particularly energy-efficient.



### GREAT RELIABILITY

Great reliability and long service life thanks to the well thought-out, low-maintenance design and compact housing.



### SAFE AND PROTECTED

Wear-resistant, infinitely variable braking system. The adjustment mechanism is protected from dirt and debris.



### SUITED FOR ANY APPLICATION

Available in different versions, such as explosion-proof, gas-tight encapsulated, pressure-resistant or for chemical media.



### FLEXIBLE, ADAPTABLE, COMBINABLE

Various nozzle holders and other accessories and configuration features adapt the device to any challenge.

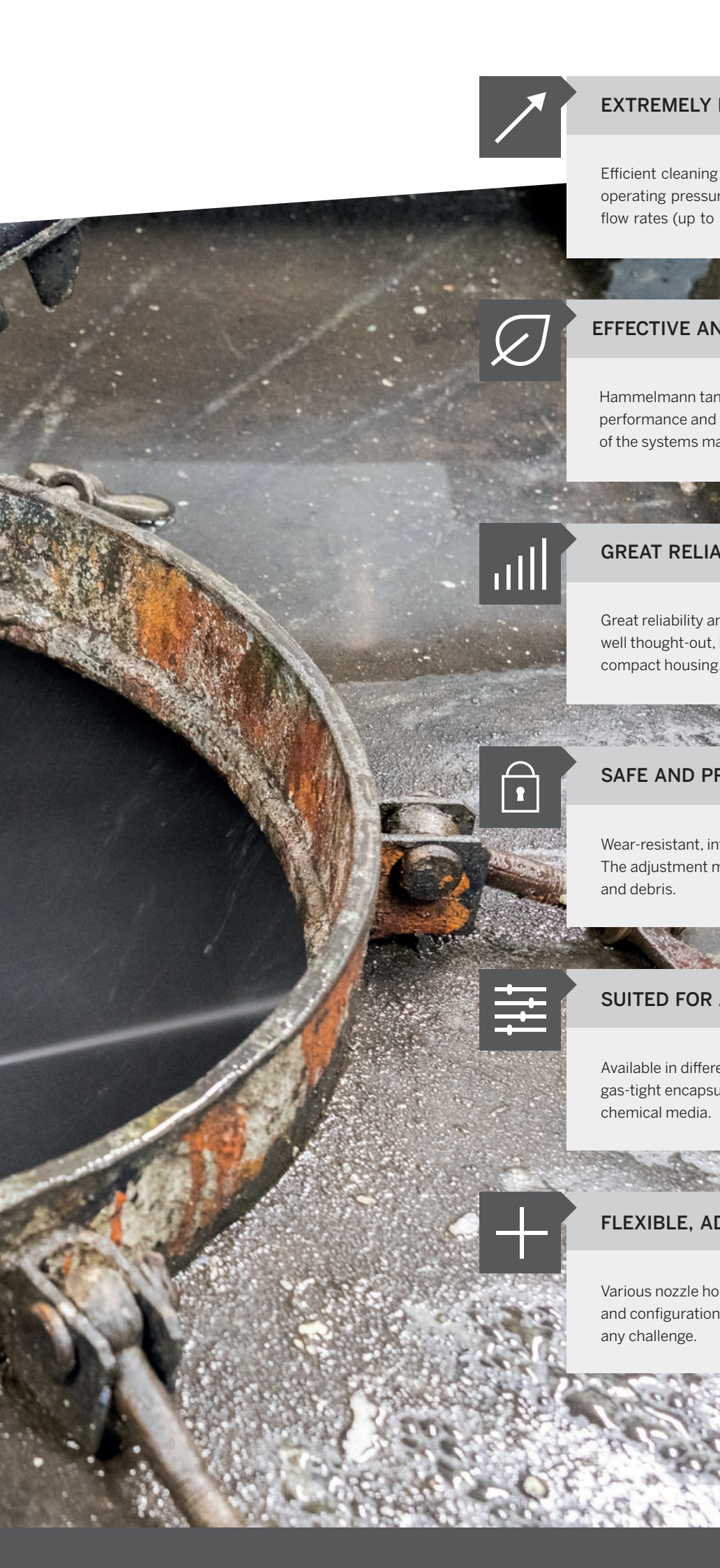

## AQUAMAT TANK CLEANING UNITS



AQUAMAT S



AQUAMAT L



AQUAMAT XL



AQUAMAT XXL



AQUAMAT Select

### OVERVIEW OF AQUAMAT MODELS (MORE MODELS ON REQUEST)

Model		Operating pressure	Flow rate*	Tank opening ▼	Weight
S 600		bis 600 bar	bis 100 l/min.	ab Ø 98 mm	~ 4,9 kg
L 500 Plus EX		bis 500 bar	bis 300 l/min.	ab Ø 130 mm	~ 11,8 kg
L 1500 Plus		bis 1500 bar	bis 300 l/min.	ab Ø 130 mm	~ 11,5 kg
L 1500 Plus Titan		bis 1500 bar	bis 300 l/min.	ab Ø 130 mm	~ 8,1 kg
L 1800 Plus		bis 1800 bar	bis 200 l/min.	ab Ø 135 mm	~ 11,5 kg
XL 1600 Plus		bis 1600 bar	bis 450 l/min.	ab Ø 150 mm	~ 18,4 kg
XL 1600	 	bis 1600 bar	bis 250 l/min.	ab Ø 205 mm	~ 38,5 kg
XXL 1600		bis 1600 bar	bis 700 l/min.	ab Ø 300 mm	~ 93,0 kg
AQUAMAT Select		bis 1600 bar	bis 500 l/min.	ab Ø 400 mm	~ 72,0 kg

\*Energy-efficient flow rates with low pressure loss. Higher flow rates however are possible.

 Zone 0 /  
Explosion-proof

 Pumping of chemical  
media possible

 Pressure-resistant /  
Gas tight





**AQUAMAT L 1500 Plus**

With "S"-type nozzle holder



**AQUAMAT L 1500 Plus**

With "S"-type nozzle holder

## CLEANING OF SMALL AND MEDIUM-SIZED CONTAINERS

For small and medium-sized containers, the AQUAMAT tank cleaning unit (TCU) is positioned centrally and set into rotation by the recoil of the water jets. Depending on the container, the AQUAMAT can be moved into different positions.

An ideal ratio of the rotational movements and the adjustable speed ensure an even and complete cleaning result.

The rotation speed is set and kept constant by a maintenance-free eddy current brake.

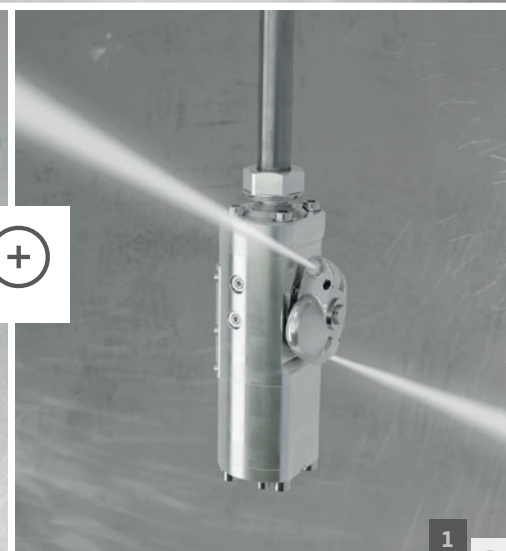
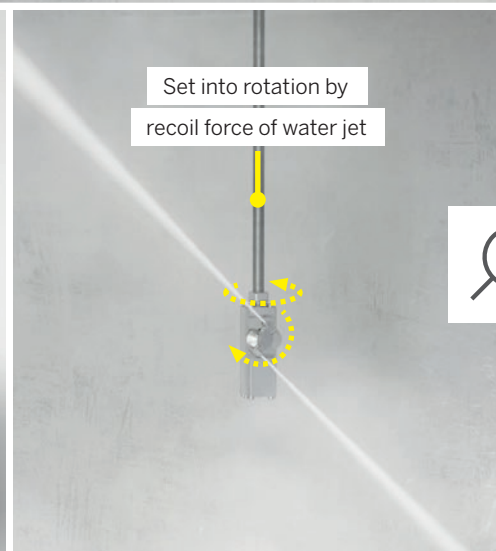
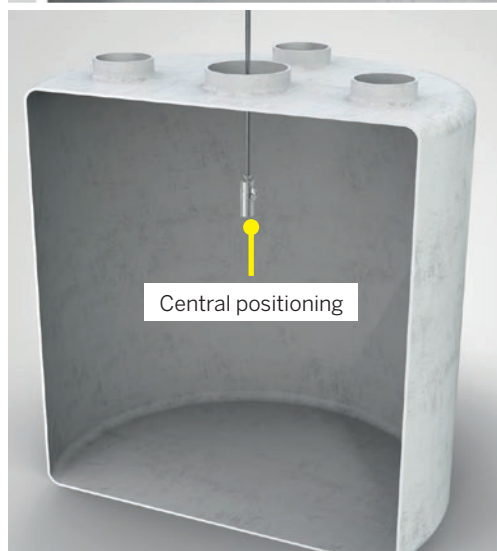
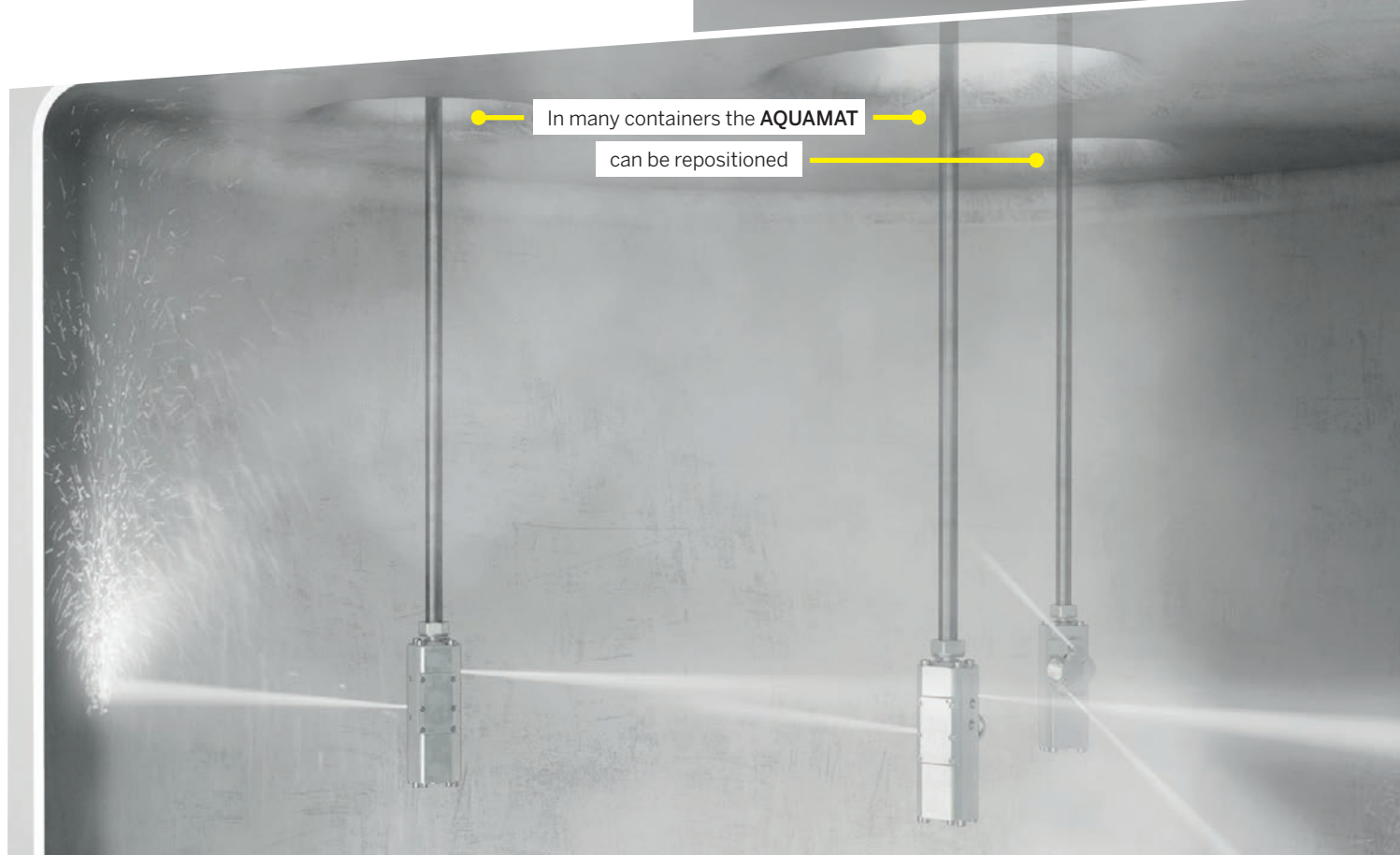

ENERGY  
EFFICIENT

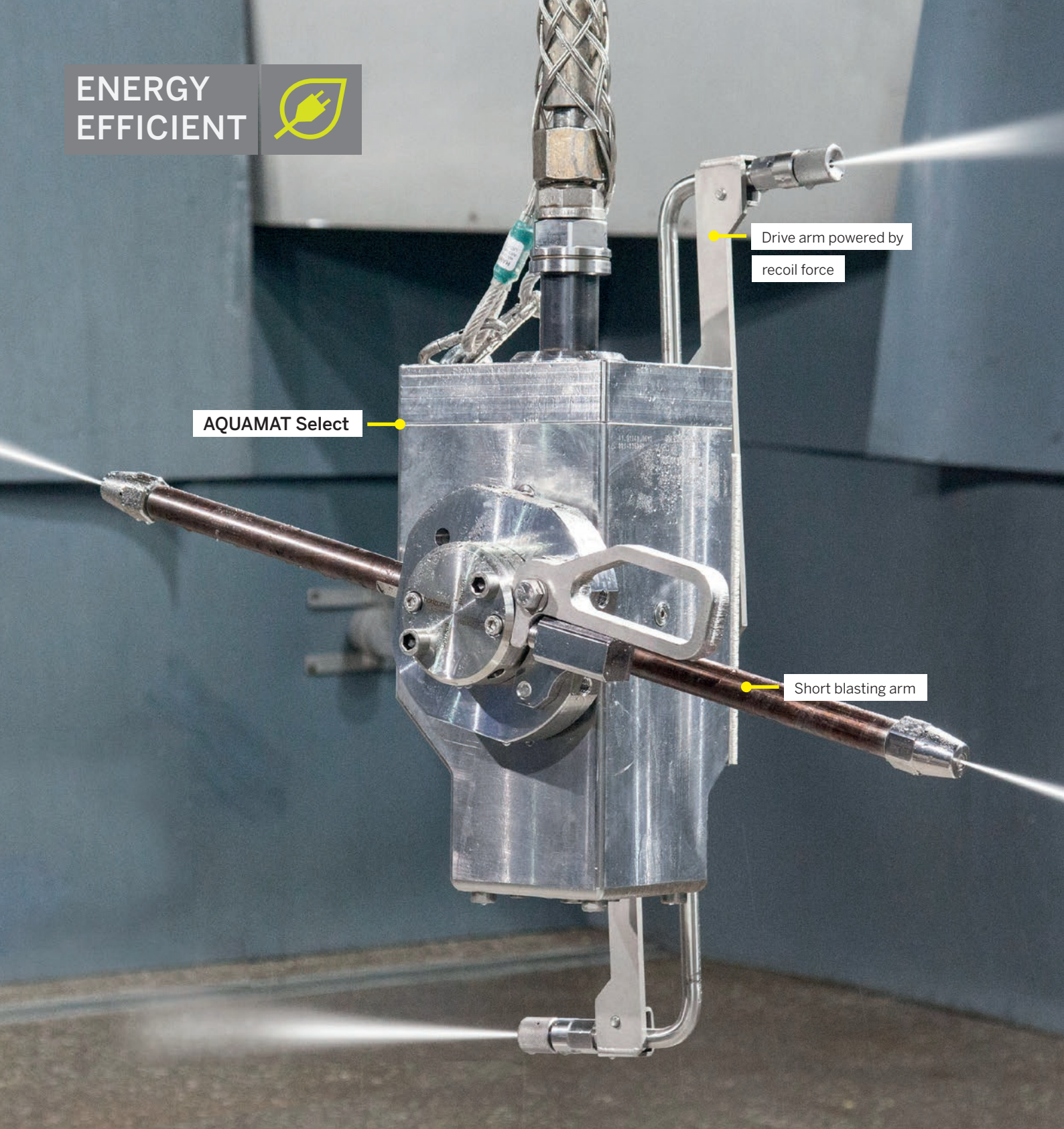

AQUAMAT Select

Drive arm powered by  
recoil force

Short blasting arm





Long blasting arm

## CLEANING OF LARGE CONTAINERS

The cleaning time is reduced by an oscillating movement of the nozzle arms. The oscillation angle can be limited to 35° or 83°. The rotation around the vertical device axis can be preselected to 36° or 81°. When used in large tanks, the tank cleaning device is positioned on the tank wall and offset in sections.

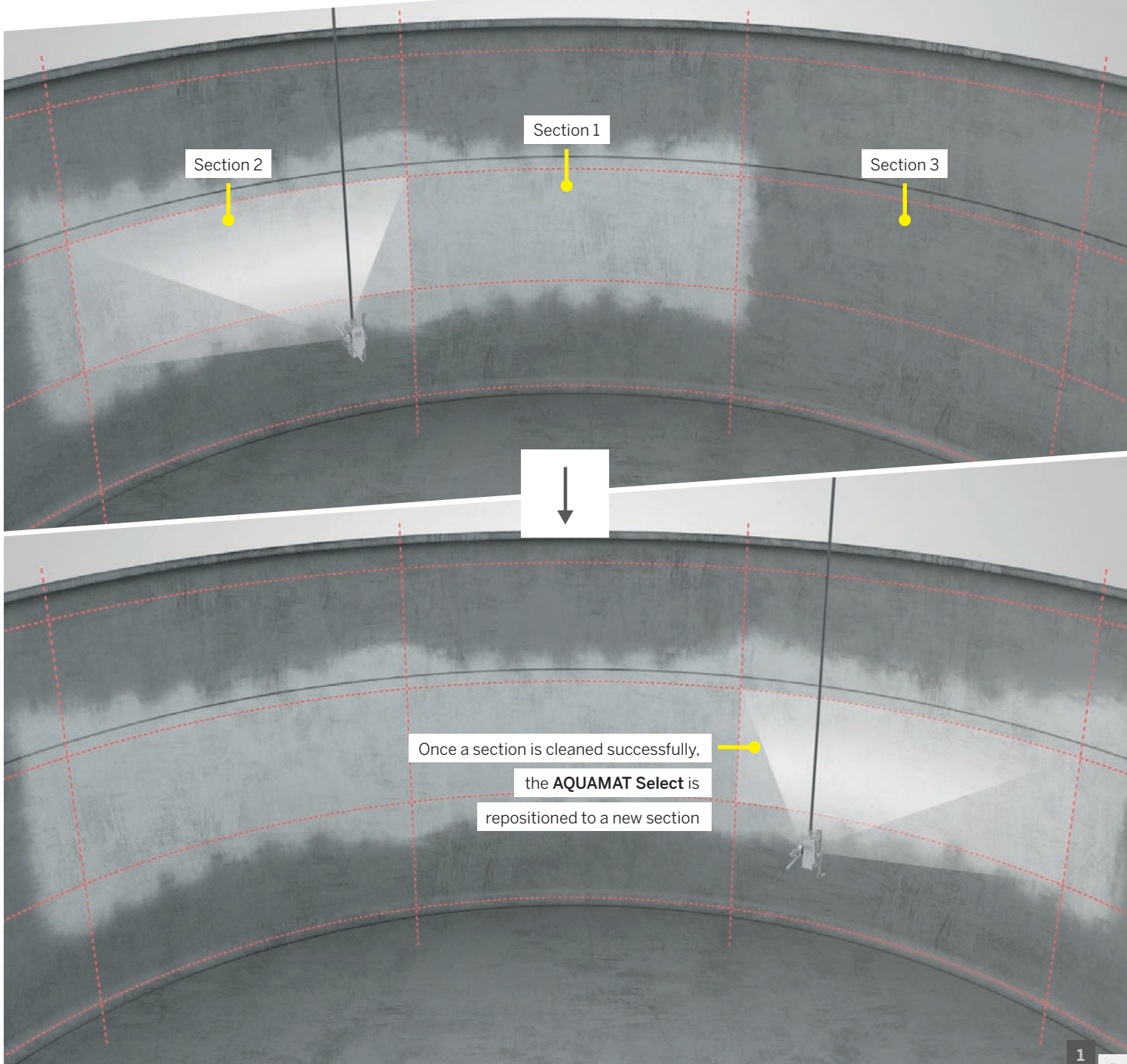
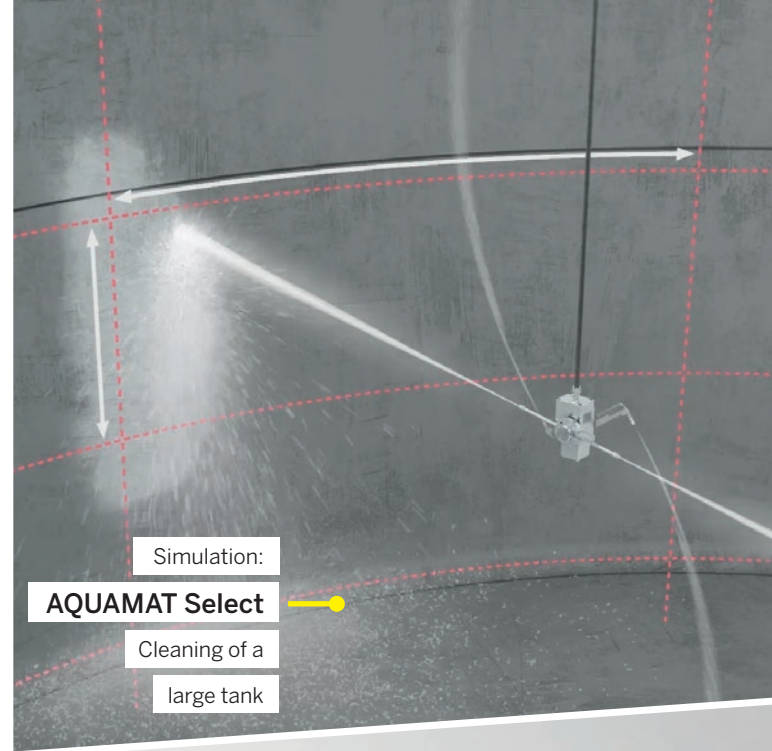
The drive of the AQUAMAT Select is generated by a second, recoil-driven nozzle arm. For its permanent rotation, different nozzle diameters are used depending on the operating pressure. This allows the cleaning time or cleaning performance to be optimized. Further variants for adaptation to the cleaning situation (floor, ceiling) are possible.





**AQUAMAT**  
ACCESSORIES, CONFIGURATION  
AND CUSTOMIZATION OPTIONS

## NOZZLE HOLDERS FOR AQUAMAT TANK CLEANING UNITS

Hammelmann offers nozzle holders in different shapes, lever arms and lance lengths in order to meet the individual requirements of the performance range and cleaning task. Particularly compact designs allow access to smaller cleaning openings.

## MANY HIGH-PRESSURE ADAPTERS FOR MANY APPLICATIONS

## CONVENIENTLY CONFIGURE NOZZLE SET UPS VIA APP

The Hammelmann *Water Jetting Calculator* is a free calculation app for water jet applications. Get an overview of all available nozzle holders and corresponding nozzle inserts and combine them with your AQUAMAT model.



### Calculation-App for tank cleaning units

Free app for iOS, Android, Blackberry and your browser

**Water Jetting Calculator:** [hammelmann.com/app](http://hammelmann.com/app)



Many different  
nozzle holders

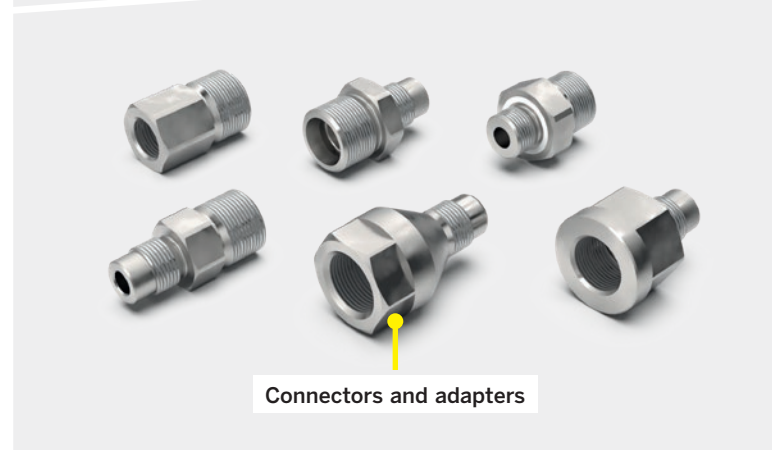

Connectors and adapters



### Extension lances

from 110 mm to 1100 mm



## OPTIONS AND ACCESSORIES FOR AQUAMAT TANK CLEANING UNITS

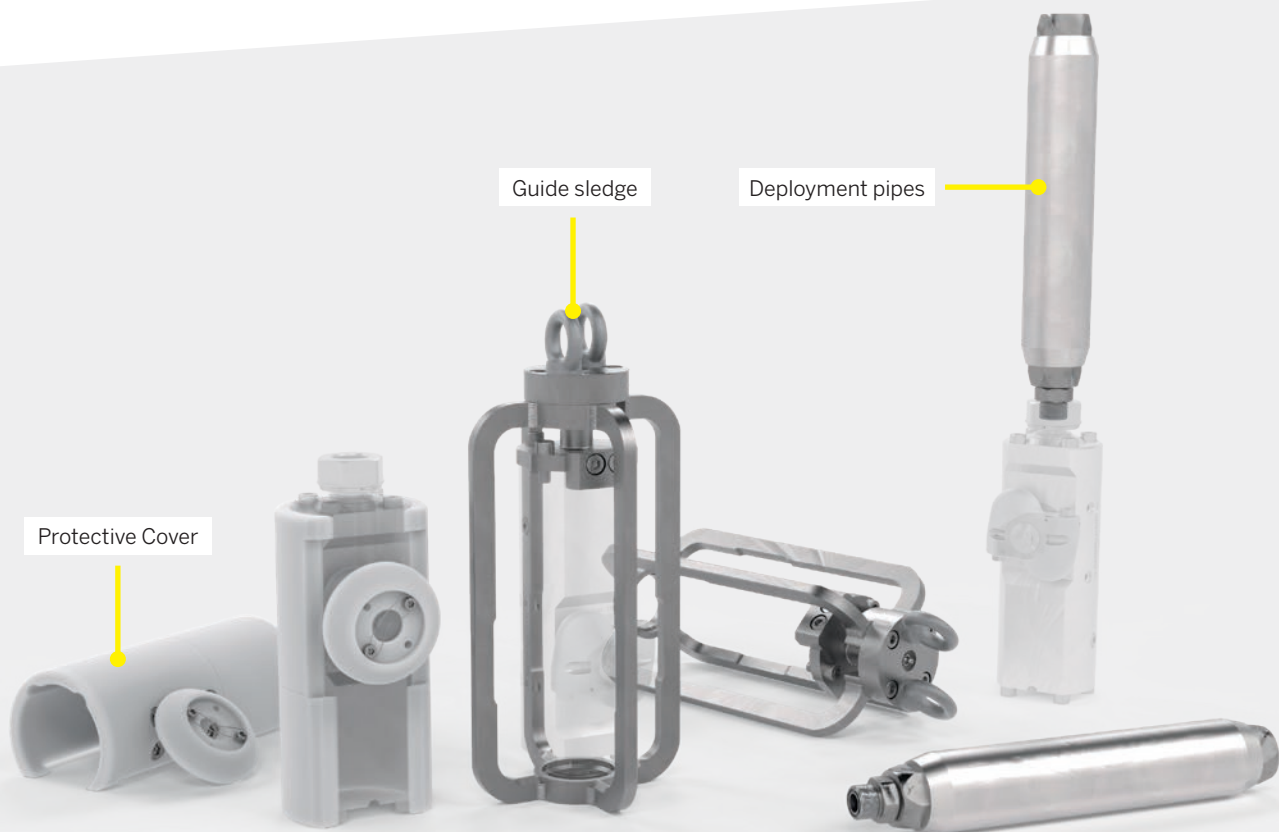

### GUIDE SLEDGE

Guides enable AQUAMAT tank cleaning units to be used for pipe cleaning. The unit is mounted in the centre and a swivelling pulling device is provided. Optional „kick plate“ available so that the assembly self-propels through the pipe.

### DEPLOYMENT PIPES

Deployment pipes stabilise the tank cleaning unit. Recommended for use when the unit is freely suspended by the hose with the unit brake adjusted to maximum (max. 1800 bar).

### PROTECTIVE COVER

Impact resistant plastic covers for tank cleaning units and nozzle holder arms.





## CLEAN PIPES WITH THE AQUAMAT

When combined with a guide sledge, the units can be used for pipe cleaning. They move forward in the pipe automatically thanks to an additional kick plate. Particularly hard deposits and incrustations are removed here.



Pulling device with eyelet

Guide sledge for pipe cleaning  
with **AQUAMAT** units

Optional kick plate for  
self-propelling forward motion



Central positioning of the **AQUAMAT**  
in the guide sledge

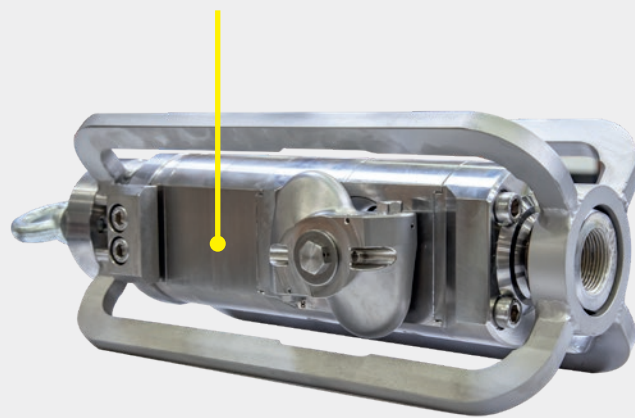

## TECHNICAL DETAILS

Model	Nozzle holder type	Operating pressure	Flow rate	Min. pipe Ø
L 1500 Plus	18 mm S-type, 2 nozzles	up to 1500 bar	up to 300 l/min.	200 mm
XL 1600 Plus	35 mm S-type, 2 nozzles	up to 1600 bar	up to 450 l/min.	320 mm
XXL 1600 Plus	13 mm S-type, 2 nozzles	up to 1600 bar	up to 700 l/min.	470 mm

2



**AQUAREX®**  
TAILOR-MADE  
TANK CLEANING DEVICES

## AQUAREX® TAILOR-MADE TANK CLEANING DEVICES

Hammelmann's highly customized tank cleaning devices are tailor-made to perfectly clean the inside of even the most unique tanks and vessels .



### HERE ARE A FEW EXAMPLES OF TAILOR-MADE AQUAREX® TANK CLEANING DEVICES

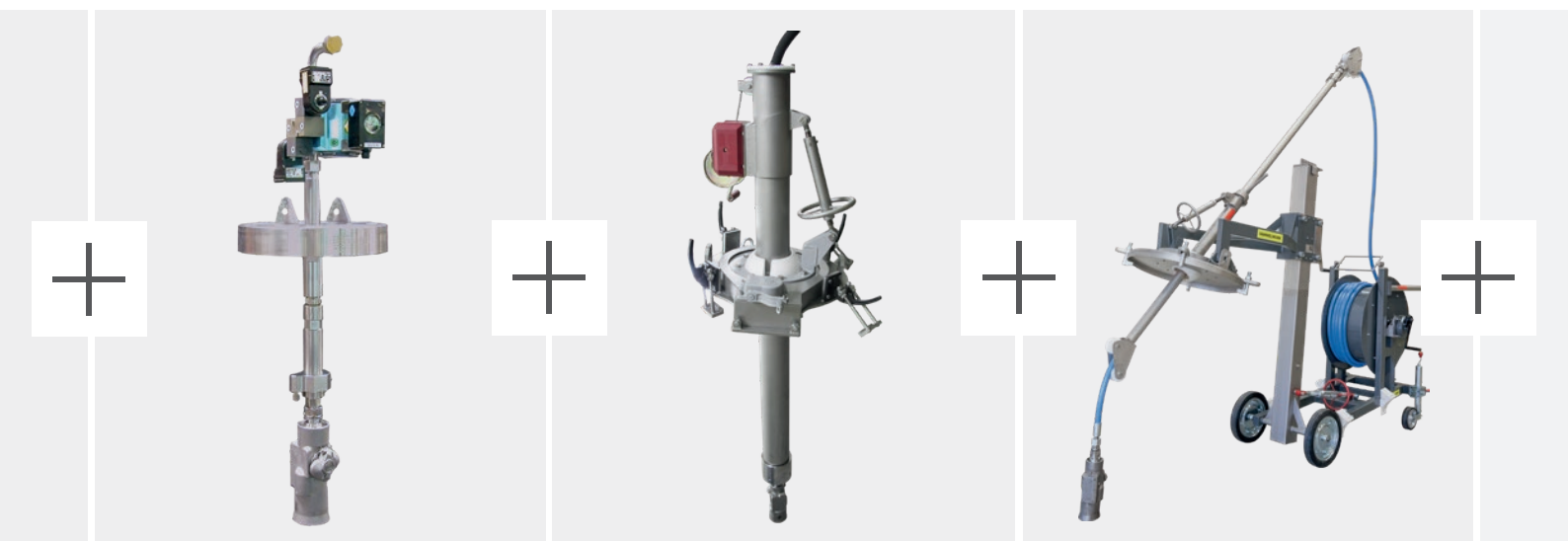

#### LANCE SYSTEM

With integrated ball valve for permanent installation. The automatic tank cleaning unit remains in the vessel during production.

#### TELESCOPIC LANCE SYSTEM

The lance is attached onto a manhole. It can be manually rotated, swivelled, retracted and extended. It is pulled out by its own weight.

#### LANCE HOSE SYSTEM

The lance is positioned over the manhole by the mobile chassis. The lance can be manually rotated, swivelled, retracted and extended.



### GAS-TIGHT LANCE SYSTEM

Four-stage telescopic lance driven by high pressure water. The cleaning device is controlled and monitored by a freely programmable PLC.



### HOSE REEL SYSTEM WITH WEATHERPROOF CABINET

The cleaning positions are freely programmable and controlled by the process plant controller.



### GAS-TIGHT HOSE REEL SYSTEM

The system is controlled by PLC with a frequency converter for the reel electric motor.



### CLOSE TO UNLIMITED POSSIBILITIES!



AQUAREX® tank cleaning devices are individually developed and manufactured based on your unique requirements. Give us a call or send us an e-mail and we will work with you to find a system that is tailored to meet your challenges!

☎ +49 (0) 25 22 / 76 - 0  
✉ mail@hammelmann.de

You can find many other examples online at [www.hammelmann.com](http://www.hammelmann.com)



## HAMMELMANN - DISCOVER THE MARKET LEADER

Hammelmann has been the market-leading supplier of high-pressure pumps and systems for high-pressure applications for over 70 years.

## STATE-OF-THE-ART TECHNOLOGY CENTER

For you and for our own R&D we run extensive tests in our modern Technology Center to see how and where water jet technology can be used in an economical, beneficial and ecological way. This is where modern technology and our innovative spirit go hand in hand to test product developments, new ideas, and specific customer requests in a practical setting and to put them through their paces.

Hammelmann attaches greatest importance to the quality of its products and to customer satisfaction. For this reason, products are not only tested under ideal conditions and then sold, but put to the test under extreme conditions.

In order to simulate the toughest and most demanding conditions possible at your site, we have a number of tanks and containers, concrete and metal walls, pipes, lines and components that we prepare and then process accordingly. The extensive tests can be carried out indoors with the help of automated robots and systems, or outdoors.

If desired, simulations can also be developed in cooperation with you. Together we will examine possible solutions for your particular application and provide you with fully documented test protocols and reproducible results. We are looking forward to your challenge.

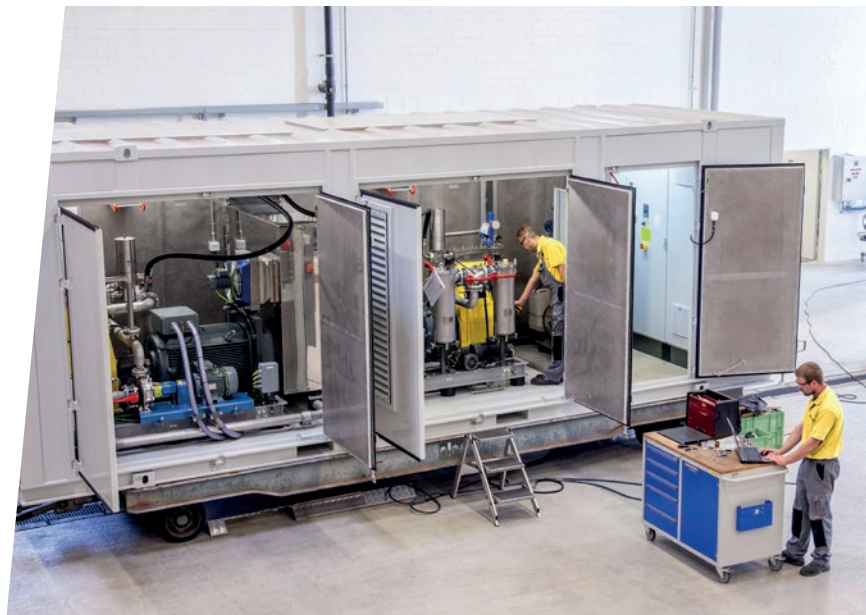

## SPARE PARTS SERVICE IN A CLASS OF ITS OWN, AVAILABLE AROUND THE CLOCK

Hammelmann's unique spare parts service offers you many advantages - a state-of-the-art logistics center, same-day dispatch and short delivery times.

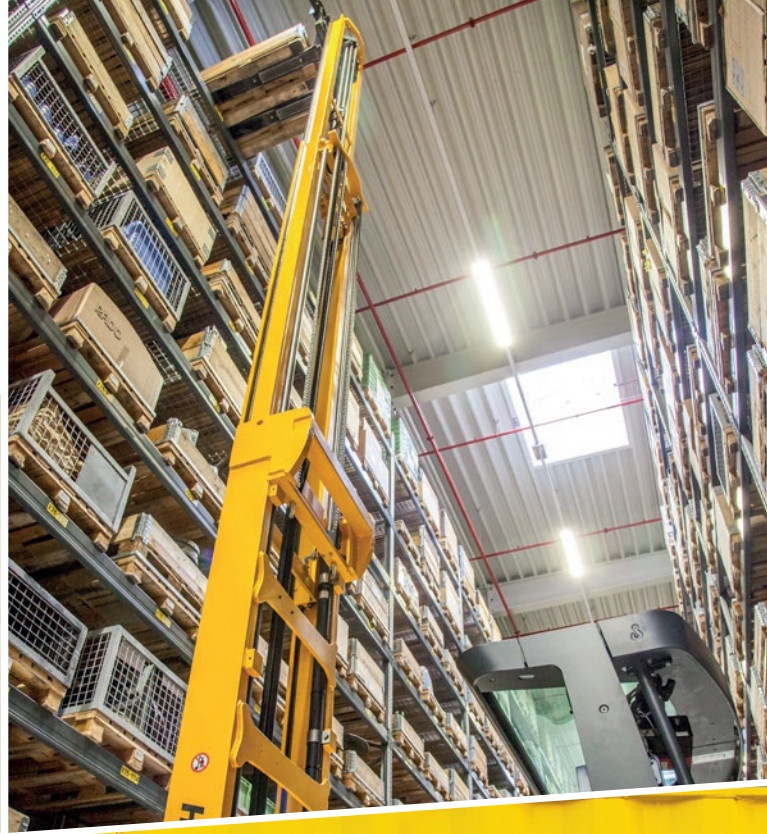

# HAMMELMANN®

## WATER JETTING



**SAME DAY DISPATCH**

For orders placed by 2 p.m.



**18,000 STORAGE SLOTS**

For plastic bins



**900 SPACES**

For Euro-pallets

### MAINTENANCE- / REPAIR SERVICE

☎ +49 (0) 25 22 / 76 - 455  
✉ mail@hammelmann.de

### SPARE PARTS SERVICE / SPARE PARTS SALES

☎ +49 (0) 25 22 / 76 - 405  
✉ mail@hammelmann.de

### 24-HOUR SERVICE-HOTLINE

☎ +49 (0) 171 / 470 72 65  
(Outside regular service hours)



## CERTIFICATES

- Achilles Certificate
- ASME Certificate
- SIR Certificate
- ISO 9001:2015
- ISO 14001:2015
- ISO 50001:2011
- TÜV 04 ATEX 2524 X
- BS OHSAS 18001:2007
- ...



### The free Hammelmann app

For iOS, Android and your browser

**Water Jetting Calculator:** [hammelmann.com/app](http://hammelmann.com/app)

Hammelmann GmbH  
Carl-Zeiss-Straße 6-8  
D-59302 Oelde

☎ (0) 25 22 / 76 - 0  
✉ [mail@hammelmann.de](mailto:mail@hammelmann.de)  
🌐 [www.hammelmann.com](http://www.hammelmann.com)



**HAMMELMANN®**